

BOMAG

FAYAT GROUP

Steel Wheel Roller

BW5AS



KEY FEATURES

- Rugged, high-strength frame
- Corrosion-free water spray system
- Vandal protection
- Hydrostatic drive
- No daily lubrication
- Ergonomically engineered operator's compartment



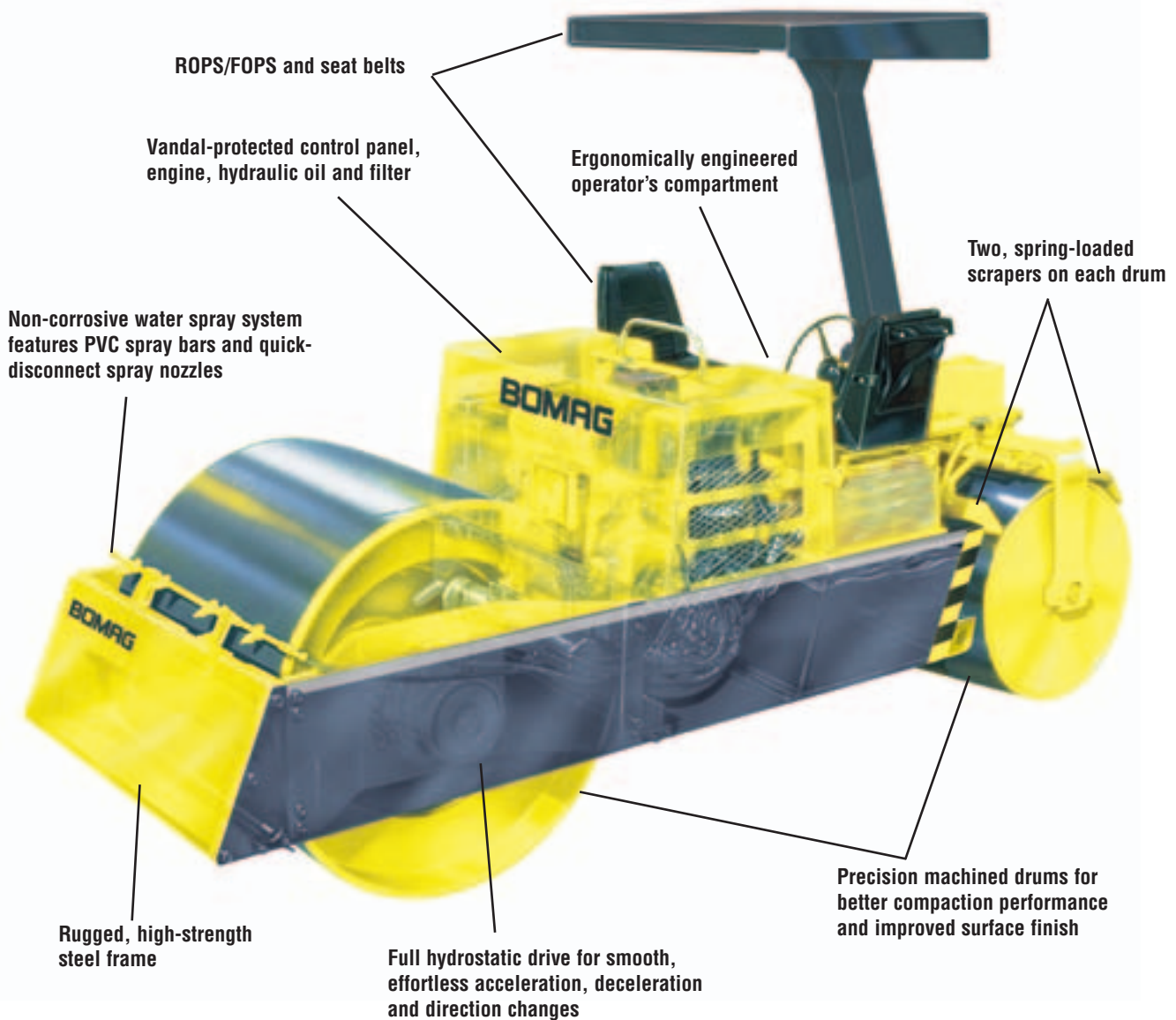

■ *Used for all phases of compaction, especially finish rolling...*

The dual center-facing seats of the BW5AS position the operator for visibility, control and comfort. The operator has full view of the exposed drums and the side of the roller. For greater versatility and easy transportation, the BW5AS is available in a 4-6 ton model equipped with tow package. The design includes a 12-volt electric socket with rear lights, positive wheel lock, guide roll yoke locks, tongue lock and safety chains. Mounted on the frame within easy reach, the hydraulic control valve lowers the towing wheels while raising the roller to a travel position providing 7 inches of road clearance under the drums.

■ **Applications:**

- Highway construction
- Commercial and residential paving
- Driveways
- Parking lots
- Asphalt resurfacing



Especially designed for all types of asphalt compaction



Controls are placed for natural operator movements

■ Handling is Easier & Safer:

- Simple ergonomic layout of controls makes operation easy.
- Brake(s) apply automatically when engine is shut down or with a loss of transmission hydraulic pressure.
- The water tank, fuel tank and engine are placed down inside the frame keeping a low center of gravity.
- The dual center-facing seats provide the operator excellent visibility of the drum and water spray system during travel in either direction.
- Falling-Object/Roll-Over Protective Structure (FOPS/ROPS) and seat belts are standard features.
- The transverse engine mounting keeps the operator comfortable by directing air, noise and exhaust 90° away.

These steel wheel rollers offer ease of operation and low maintenance

■ Achieve Maximum Productivity:

- Hydrostatic drive allows smooth, effortless acceleration, deceleration and directional changes.
- Radial piston design transmission provides excellent gradeability, as well as top production at high travel speed.
- Hydrostatic steering with automotive type steering wheel provides the operator with controlled maneuverability.
- Cummins A2300 diesel engine provides ample reserve power for even the most demanding jobs.
- The precision machined drum(s) provide smooth, compacted surface results.
- Two-section steering drum minimizes scuffing in sharp turns.
- Dual scrapers and full width cocoa mats on each drum minimize asphalt pick-up.
- Hydrodynamic braking of hydrostatic drive system provides smooth, controlled, positive stops.

■ Less Service & Maintenance:

- The purchase price is important, but so are the operating costs. Check these features:
- The frame overhang is minimal and all drive components are inside the frame.
 - There are no "grease daily" fittings.
 - High efficiency, 7-micron filter helps prolong hydraulic component life. Indicator light on console immediately alerts the operator when the filter requires service.
 - Daily maintenance checkpoints and filters are easily reached.
 - Pressure test ports are centrally located, using standard capped fittings for quick hassle-free servicing.
 - The non-corrosive water spray system features PVC spray bars and quick-disconnect spray nozzles.
 - Center opening hood offers excellent engine area accessibility.

Featuring...



The full hydrostatic drive with a low-speed, high-torque motor delivers smooth acceleration, deceleration and directional changes.



Each drum has a full width cocoa mat, two scraper bars that clean in both travel directions, and four spray nozzles



The engine location is low in the frame for ease of service and operator visibility

With these features and many more, it's easy to see why this model maintains a high residual value while delivering lower lifetime operating costs.

Technical Specifications

BW5AS

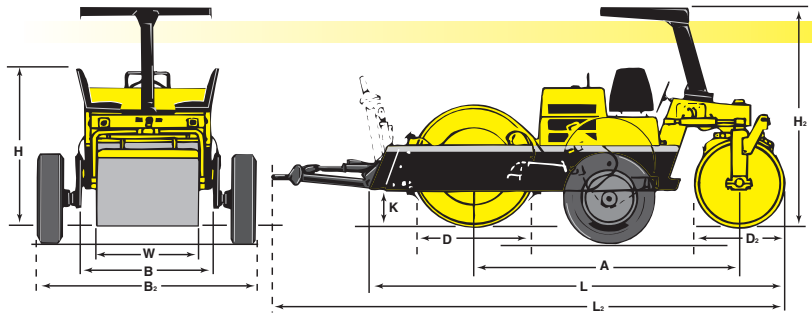

Dimensions in inches (mm)	A	B	B2	D	D2	H	H2	K	L	L2	W
BW5AS	108 (2743)	52 (1321)	84 (2134)	48 (1218)	34 (864)	63 (1600)	97 (2464)	15 (381)	159 (4039)	206 (5232)	F 40/R 42 F (1016)/R (1067)

Standard equipment (3-5 ton)

- Cummins A2300 Diesel Engine
- Pressurized Water Spray System
- Horn
- Front and Rear Drum Scrapers
- Cocoa mats
- Vandal Guards
- ROPS/FOPS and Seat belts

Optional equipment (3-5 ton)

- Headlights (Front and Rear)
- Turn Signals and 4-way Flashers
- Special Paint, 1 Color
(Enamel Only)

Standard equipment (4-6 ton)

- Cummins A2300 Diesel Engine
- Pressurized Water Spray System
- Horn
- Front and Rear Drum Scrapers
- Cocoa mats
- Vandal Guards
- ROPS/FOPS and Seat Belts
- Towing Package
- Towing Lights
- Towing Safety Chains

Optional equipment (4-6 ton)

- Headlights (Front and Rear)
- Turn Signals and 4-way Flashers
- Special Paint, 1 Color
(Enamel Only)
- 9:00 x 20 - 12 Ply Tires
- Electric Brakes
- Electric Brakes Control Kit

Technical data

Weights		BOMAG BW5AS	
Operating weight 3-5 ton.....	lb (kg)	9380	(4255)
Operating weight w/ full ballast 3-5 ton.....	lb (kg)	12080	(5480)
Operating weight 4-6 ton.....	lb (kg)	10347	(4693)
Operating weight w/ full ballast 4-6 ton.....	lb (kg)	13047	(5918)
Max. static linear load/drive drum 3-5 ton.....	lb/in (kg/cm)	171	(30.5)
Max. static linear load/guide drum 3-5 ton.....	lb/in (kg/cm)	122	(21.9)
Max. static linear load/drive drum 4-6 ton.....	lb/in (kg/cm)	191	(34.1)
Max. static linear load/guide drum 4-6 ton.....	lb/in (kg/cm)	126	(22.5)

* Operating weight includes full fuel tank, half tank waterspray, FOPS/ROPS and 175 lb operator

Dimensions

Track radius, inner.....	in (mm)	112.5	(2858)
Height with FOPS/ROPS.....	in (mm)	97	(2464)

Driving Characteristics

Speed (1).....	mph (km/h)	0-11	(0-17.7)
----------------	------------	------	----------

Drive

Engine manufacturer.....	Cummins
Type.....	A2300
Cooling.....	water
Number of cylinders.....	4
Performance SAE, brake.....	47 (35)
Speed.....	2600 (2600)
Fuel.....	diesel
Electric equipment.....	12
Drive system.....	hydrostatic
Driven drum.....	R

Brakes

Service brake.....	hydrostatic
Secondary/Parking brake.....	SAHR

Steering

Steering system.....	automotive-type
Steering method.....	hydraulic
Steering angle +/-.....	39
Oscillating angle straight +/-.....	25
Oscillating angle full turn +/-.....	15

Water Spray System

Type of spray system.....	pressurized
---------------------------	-------------

Capacities

Fuel.....	gal (l)	17	(64)
Water.....	gal (l)	100	(379)
Hydraulic oil reservoir.....	gal (l)	15	(57)
Coolant system.....	gal (l)	4.75	(18)

Technical modifications reserved. Machines may be shown with options.